



PNEUMATIC ROCKDRILLS

DIAMOND DRILLS

REPLACEMENT PARTS

PARTS HEADQUARTERS INC.

1175 Appleby Line, Unit C2, Burlington, Ontario, Canada L7L 5H9 Phone 905-332-3271 Fax 905-332-9497 Email info@partshq.com

PHQ250 Jackleg

All internal parts in the PHQ250 Jacklegs are used in PHQ250 Stoppers, Sinkers and Quarry drills.

Drill delivers high penetration, and strong torque.

Convenient operating controls, with push button leg retraction and adjustable motorcycle control feed on the backhead of the drill.

Positive lubrication with strong front end blow.

Larger mating faces between major cylinder components for longer life and less wear.

Improved pusher leg is available with a stainless steel piston rod to prevent corrosion and pitting.

Locking steel retainer for collared steel standard.

Uses rock drill oil or grease.



PHQ250 Jackleg Drill

PHQ's 250 Drills have larger mating faces between major cylinder components for reduced air leakage and longer wearing life.

ISO 9001-2008 **QMI** CERT 002485
US SIC 5082 **SAI GLOBAL** NACE 651.6
REGISTERED

www.partshq.com

Features

Large mating faces on components bodies for less wear and longer life

Reduced weight for ease of handling.

PHQ250JLM Jackleg Specifications

CYLINDER BORE

3¹/₈ inches – 79.4mm

CYLINDER STROKE

2⁷/₈ inches – 73.25mm

AIR CONSUMPTION

175cfm @90psi – 4.9cu m/m @620kPa

BLOWS PER MINUTE

2250bpm @ 90psi – 2250bpm @620kPa

SHANK SIZE - Collared

7/₈ inch x 4¹/₄ inch - 22mm x 108mm

LENGTH

Drill 22 inches – 559mm

Leg Retracted 61 inches – 1550mm

Leg Extended 112 inches – 2845mm

WEIGHT

Drill 73 lb – 33kg

Leg 29.5 lb – 13kg

PHQ250 Jackleg configurations:

- JHM Integral steel muffler
- JHS Standard exhaust
- L Complete with Leg

PHQ250JHML

Muffled jackleg collared c/w steel retainer & leg

PHQ250 Jackleg Drill

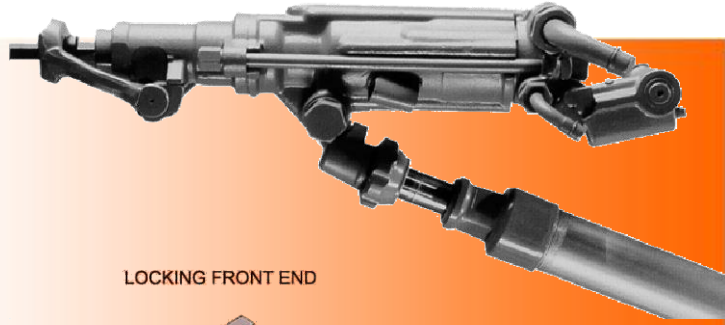

LOCKING FRONT END

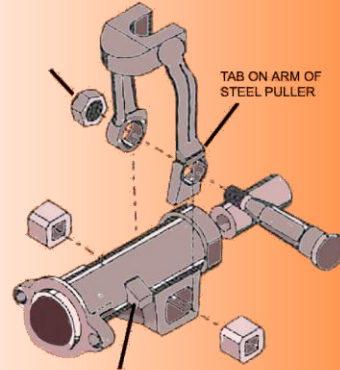

TAB ON STEEL PULLER STOPS AT TAB ON FRONT END



PHQ carries a full range of parts for PHQ250 drills in stock.

All parts made in Canada to precise specifications using only the highest quality tool steel